

AMX 100 Measuring Device

High Resolution - Easy to use - Precise

For Milling Cutters, Twist Drills, Core Drills, Reamers & Other Cylindrical Tools

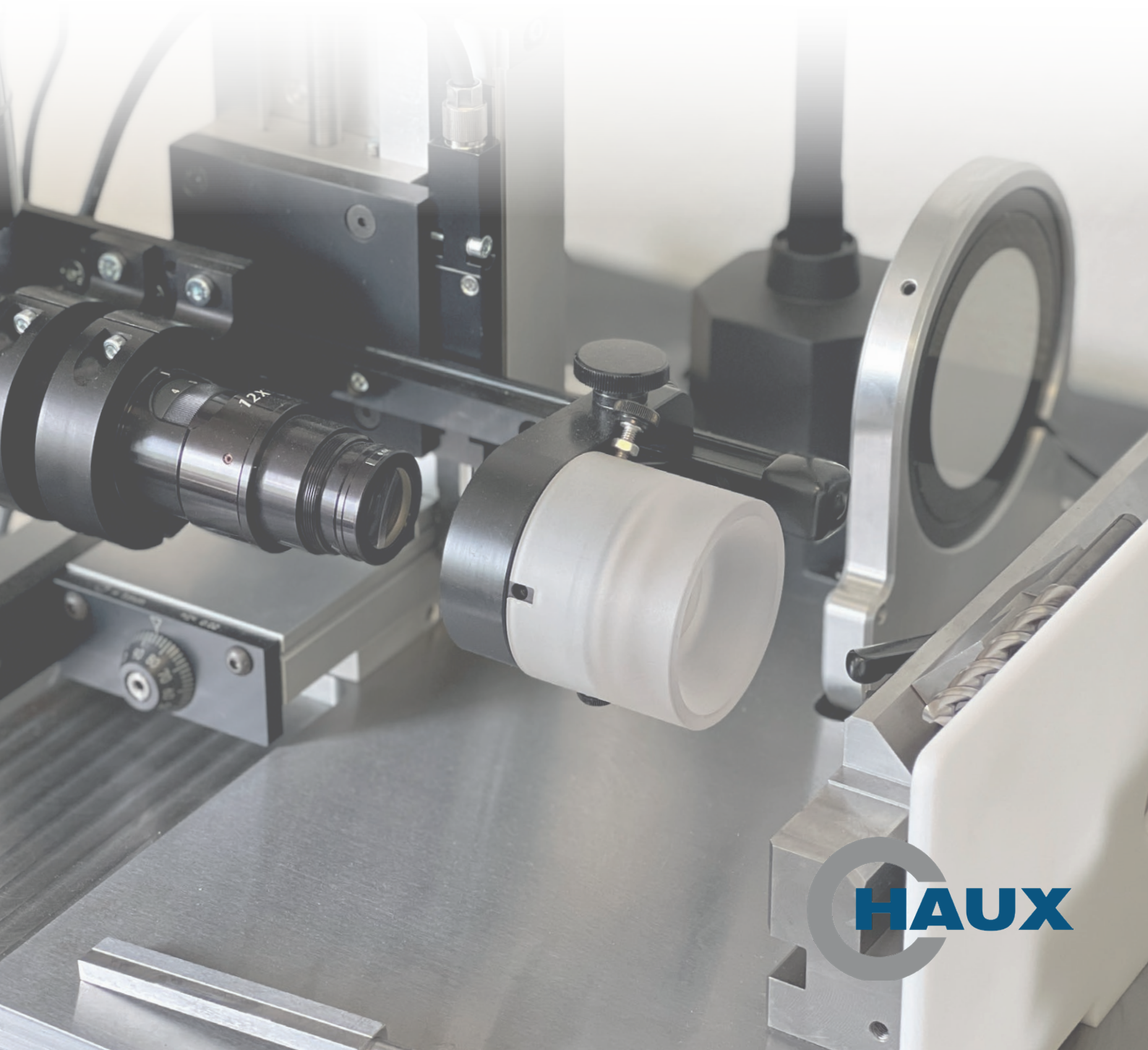

AMX 100/E

Precision measurements

The AMX 100 is the successor to the PG 100 with state of the art camera microscope and easy to use software. It features transmitted as well as reflected light sources and a high precision camera and optical system by KITOTEC. The AMX 100 is available as either the AMX 100 E or the AMX 100 Premium with a higher end camera system and light sources



The prism can now be easily rotated and the new light reflector can be quickly rotated in and out of the camera's field of view.

AMX 100 E

Measurement system with standard video microscope camera (KITOZOOM EB-MT-LED) and standard LED lighting

Basic: 19.350 €

Full System: 24.460 €

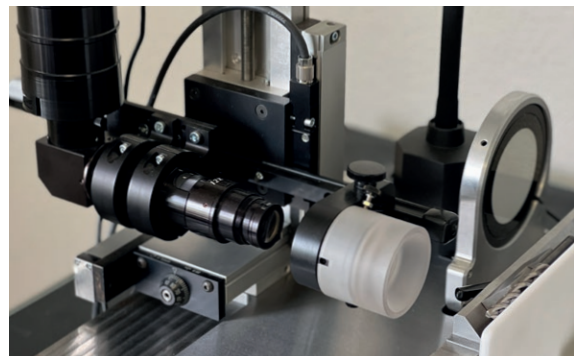

The camera sits on two precise linear guide rails with linear encoders by HEIDENHAIN.

AMX 100 Premium

Upgraded higher end camera system (KITOZOOM NAV-12000-W) and more advanced lighting

Basic: 26.960 €

Full System: 32.090 €



AMX 100 Full System

High Resolution Screen - Sturdy working table -

Specifications

Workpiece diameter:	1 - 45 mm
Workpiece length:	max 350 mm
Dimensions (L / W / D):	ca. 800 x 500 x 500 mm
Weight:	ca. 60 kg

Components

- KITOZOOM Camera with up to 12x Zoom
- Heidenhain LS383C Linear Encoders on positioning unit
- Universal prism 3 - 45 mm
- Reduction prism 1 - 3 mm
- Centering and placement tool
- Sturdy portable working table
- PC incl. mouse & keyboard
- 4K / 2160p High resolution Screen 24"
- Dimmable LED ring light
- Refractive backplate
- Dimmable LED Backlight
- Measuring software Metric MT
- Flexible workplace light

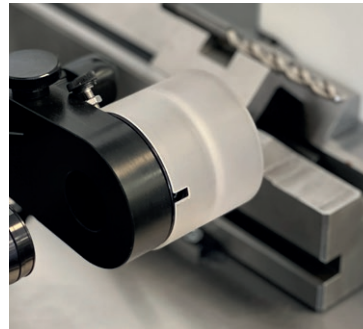
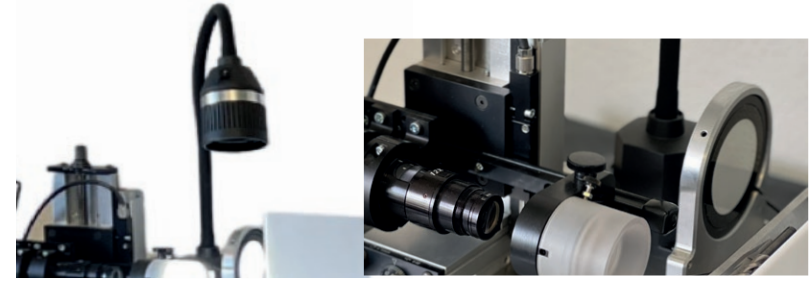
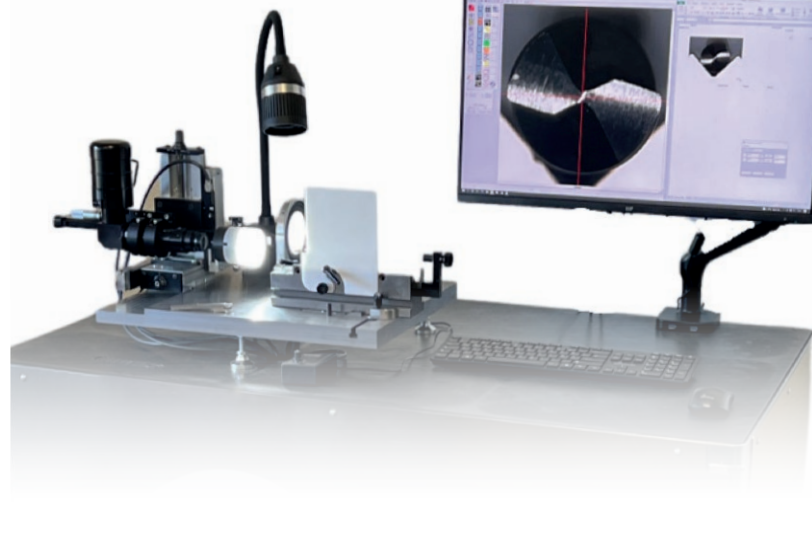

AMX 100 Basic

Minimal configuration for integration with existing computer / laptop

Specifications

Workpiece diameter:	3 - 45 mm (1 - 3 mm extension available)
Workpiece length:	max 350 mm
Dimensions (L / W / D):	ca. 800 x 500 x 500 mm
Weight:	ca. 60 kg

Components

- KITOZOOM Camera with up to 12x Zoom
- Heidenhain LS383C Linear Encoders on positioning unit
- Universal prism 3 - 45 mm
- Dimmable LED ring light
- Refractive backplate
- Measuring software Metric MT

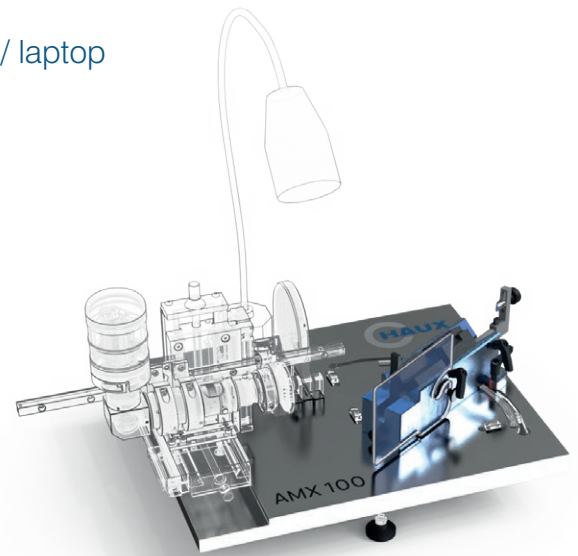



HAUX Automation

Elevate performance to the next level

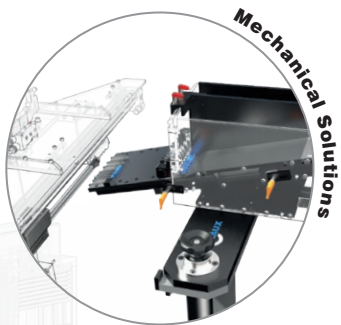

Mechanical Solutions

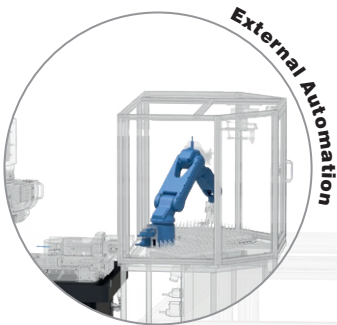

External Automation



Integrated Automation

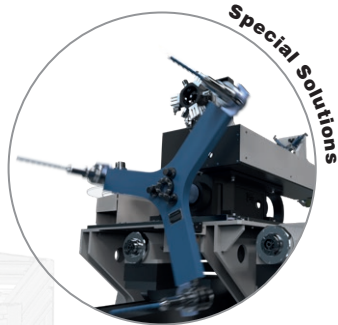

Special Solutions

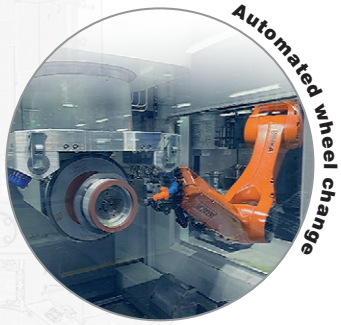

Automated wheel change

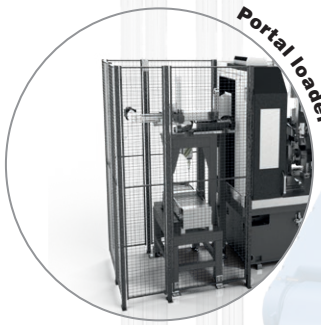

Portal loader

HAUX offers the right automation solution for every situation.



Automation Options

Examples of automation solutions used in HAUX machines

Mechanical Solutions

High quality engineering

HAUX Maschinenbau offers decades of know-how and innovations of the pioneers of high speed grinding. High speed workpiece loading and unloading using magazines and indexing mechanisms offers top speeds in many use cases.

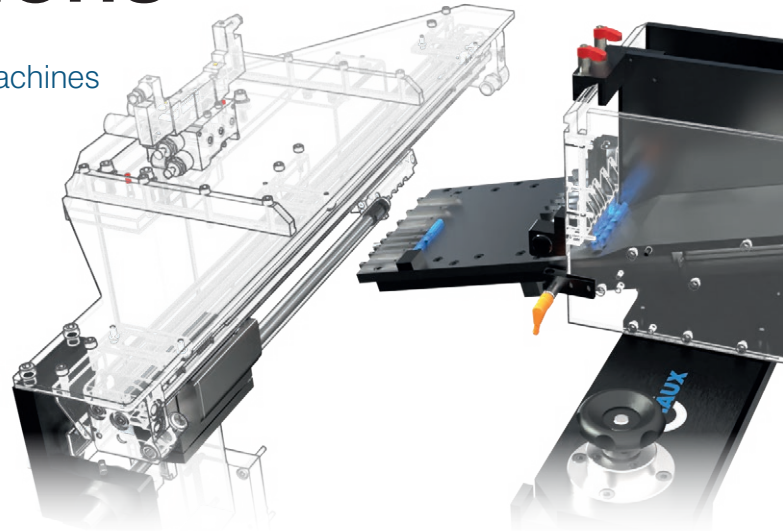

Robotics

Flexible and universal

Industrial robots offer a great balance of cost and flexibility and can even be used to automate grinding wheel changes. Lots of custom grippers, storage, indexing- and orienting solutions let us customize the scope of the robotic automation of your machine when needed.

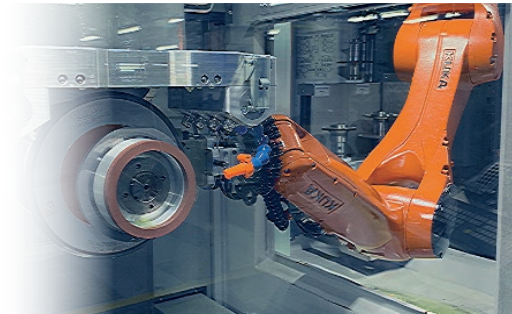

Portal & Production Line Integration

For seamless production

Portals can offer better speeds versus robots for applicable use cases and still remain a lot of the same flexibility.

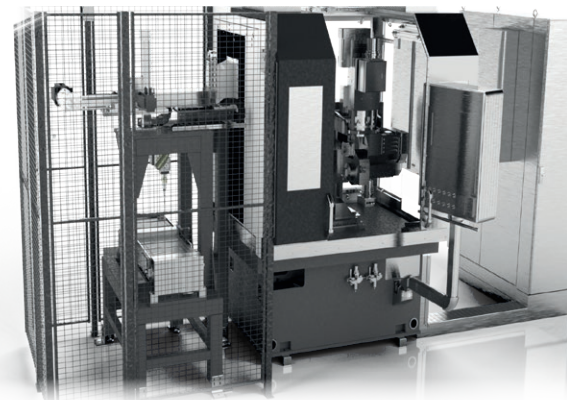

Special Solutions

For high speed and special customer needs

HAUX has a lot of experience in special applications and individual engineering projects. For special use cases we work closely with our customer to develop the optimal machine for the specific use case.

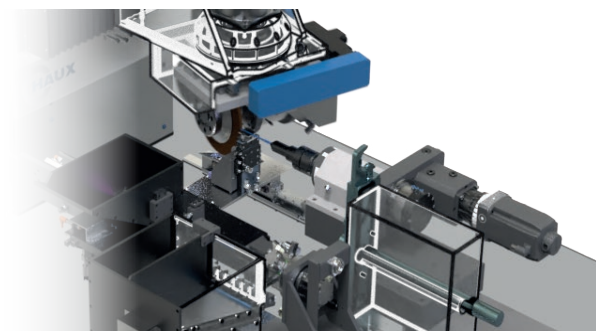

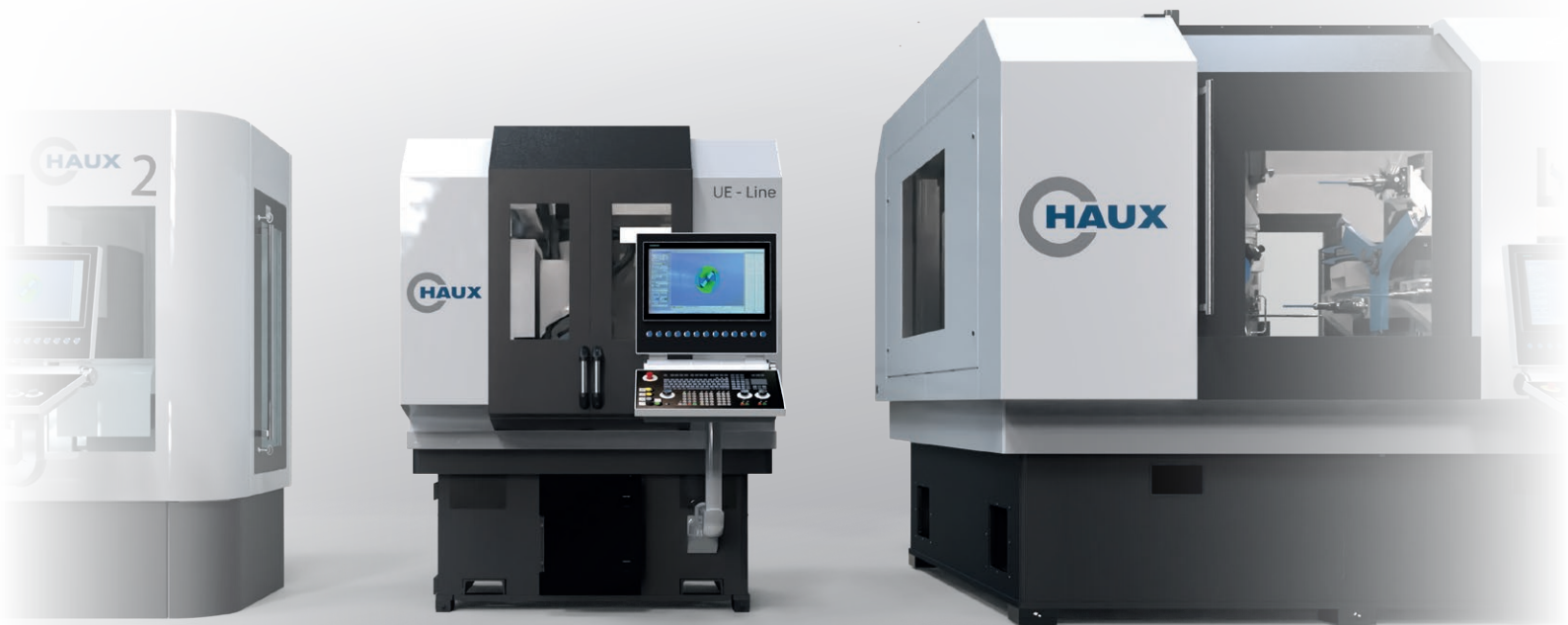

HAUX MOVING INNOVATION

For more information visit haux-grinding.com or
contact us for an individual consultation.

UE Line

Universal Eco - Modular Universal grinding

The UE-Line is our allround talent - flexible and expandable. The 5-Axis grinding kinematic of the base model offers you full flexibility and the extra strong structure of all components allows high speed and feed rates. Many different configurations are possible to specialize for specific production requirements using HAUX Modules.



UP Line

Universal Premium - High End Universal grinding

The HAUX UP-Line offers full autonomy and ultra high precision. Its high precision servo axis lead to a perfect surface finish and the the high end base body eliminates vibrations. The top model the UPT combines two stations with an automation cell inbetween. Collet changes, tool changes and even grinding wheel packet changes can be done fully automatic.



MM Line

High Performance Multi Station

The MM-Line combines two main grinding stations on one base body and offers excellent cycle times using a high end tool changing system that can move the tool between stations and load as well as unload in one single fast movement.



Special

High Performance Multi Station

HAUX has a lot of experience in special applications and individual engineering projects. For special use cases we work closely with our customer to develop the optimal machine for the specific use case.

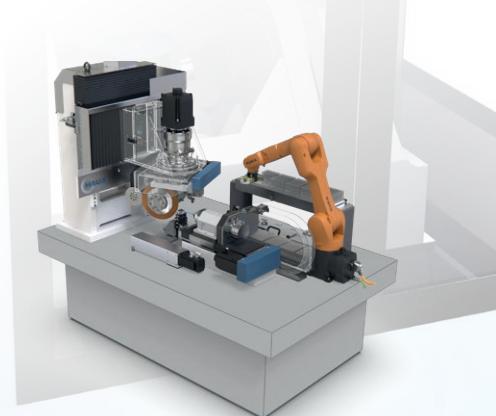



HAUX Maschinenbau offers decades of know-how and innovations of the pioneers of high speed grinding.

Contact

HAUX Maschinenbau GmbH

Ebinger Str. 50
72510 Stetten a.k.M
Baden-Württemberg

GERMANY

Phone: +49 (0)7573 95455-0
FAX: +49 (0)7573 95455-30

Internet: haux-grinding.com
E-mail: info@hauxgmbh.de

International

HAUX JAPAN Office
E-Mail: m.westermann@hauxgmbh.de
Contact: Mr. Westermann

HAUX INDIA Office
411041 Pune
INDIA
Phone: +91 83081 06677
E-Mail: m.deshpande@hauxgmbh.de
Contact: Mr. Deshpande

HAUX RUSSIA / BELARUS /
KAZAKHSTAN Office
ATE Tools GmbH
Phone: 0049-7433-908949-20
Contact: Mr. Teichert

HAUX FRANCE Office
Phone: +49 7435 8251
E-Mail: m.maisch@hauxgmbh.de
Contact: Mrs. Maisch



For more Information visit
haux-grinding.com